

Operating Instructions (OI)

for

Küba Air Coolers

in accordance with DIN EN 307

How to use the operating instructions

Be sure to read these instructions, the mounting instructions, and the Declaration by the Manufacturer, prior to the start-up of your air cooler.

Safety symbols for working areas



Within these instructions (OI), this symbol is found next to all recommendations for safety at work, i. e. for situations which are either a danger to human life or a risk of injury to persons. Please follow these instructions and act with particular care in all these situations. You are also requested to transmit all work safety instructions to other users. In addition to these instructions (OI), it is necessary to take into account the universally applicable safety and accident preventing rules.

Caution sign



Throughout these instructions (OI), this CAUTION sign marks all paragraphs requiring special attention so that the rules, regulations, recommendations as well as the correct course of the works are followed and the unit and/or parts of the installation are safeguarded from danger and from destruction.

Recycling



Whenever air coolers, unit parts or spare parts are renewed, the correct way of recycling for the exchanged parts is to be duly observed. On this subject please see sections 10.1 through 10.6 of these instructions.

Table of Contents

1	Introductory Information	5
	1.1 Basic reference literature	5
	1.2 Range of application	5
	1.3 General Safety Instructions	5
	1.4 Proprietary Right, Copyright Law	5
	1.5 Changes	5
2	Technical Data	5
	2.1 Characteristic data	5
	2.2 Operative range and purpose of destination	6
	2.3 Material data	6
	2.4 Model designation	6
3	Safety	7
	3.1 Information on safety in general	7
	3.2 Mounting	7
	3.3 Mounting of electric parts	8

4	Packing, Transportation and Storage	9
	4.1 Packing.....	9
	4.1.1 Type of packing	9
	4.1.2 KÜBA transport packing	9
	4.1.3 Rules for packing.....	9
	4.1.4 Pictorial symbols	9
	4.2 Disassembly status.....	10
	4.3 Transport	10
	4.3.1 Handling with adequate care in transit, lifting & storing	10
	4.3.2 Center of Gravity	10
	4.4 Storage.....	11
	4.4.1 Storage space	11
	4.4.2 Stacking.....	11
	4.5 Scope of delivery	11
	4.6 Securing loads by safety devices	11
	4.7 Rules for the prevention of accidents	11
5	Mounting	11
	5.1 General instructions for mounting.....	11
	5.2 Set-up conditions.....	12
	5.2.1 General set-up instruction.....	12
	5.2.2 Dimensions, floor space and weight	12
	5.2.3 Hoisting devices	13
	5.3 Mounting work	13
	5.3.1 General information on mounting works	13
	5.3.2 Mounting of electric parts.....	13
	5.3.3 Mounting of accessories.....	13
	5.3.4 Mounting of refrigeration equipment acc. to DIN EN 378	13
	5.3.5 Positioning of the defrost sensor	13
	5.3.6 Finned tube heater	13
6	Starting Operation	14
	6.1 Instructions	14
	6.2 Test run	14
	6.3 Testing prior to Operation	14
	6.4 Purging of the Refrigerant /Coolant circuits	14
7	Operation	14
	7.1 Normal operation	14
	7.1.1 Direct expansion	14
	7.1.2 Pump operation	14
	7.1.3 Water and glycol water circulation	14
	7.2 Shutdown of the forced-circulation air cooler.....	15
	7.3 How to handle failure situations.....	15
	7.4 Recurrent examinations.....	15
8	Servicing and inspection	15
9	After-Sales Service	16
	9.1 Stock keeping of spare parts	16
	9.2 Corrosion.....	16
10	Disassembling and Recycling	16
	10.1 Disassembling	16
	10.2 Materials of of the coolers	16
	10.3 Synthetic construction materials	16

10.4	Materials for motors	16
10.5	Packing material	16
10.6	Recycling concept	16
11	Annexes	17
	Checklist for recurrent testing of forced-circulation air coolers (Proposal)	Annex

1 Introductory information

1.1 Basic reference literature

Concerning the technical data we refer to our current planning aid literature on forced-circulation air coolers. As far as fan motors are concerned, the only binding data are those on the label.

1.2 Range of application

CAUTION !

The forced-circulation air coolers can be used:

- for refrigerant media with direct expansion, using the fluids shown on the nameplate
- for refrigerant media in pump operation, using the fluids shown on the nameplate
- for refrigerants, using the fluids shown on the nameplate

Comment:

Fluid group 1: Refrigerant media or refrigerants with hazard category (refrigerant media group L2 and L3 in acc. with the DIN EN 378 standard (e.g. ammonia), thermo oil)

Fluid group 2: Refrigerant media or refrigerants without hazard category (refrigerant media group L1 in acc. with the DIN EN 378 standard (e.g. Frigen), brine, glycol or water)

1.3 General Safety instructions



Installation, commissioning, service and maintenance may only be carried out by trained persons in acc. with the Accident Prevention Regulation BGV A1, "Prevention principles".

1.4 Proprietary right, copyright law

GEA KÜBA GmbH is the holder of all rights, including claims for industrial property right as well as all rights of disposal including that of copying and passing on of KÜBA documents.

1.5 Changes

Regarding descriptions and informative details as given in these operating instructions (BA), reservation is made for all technical changes which may become necessary for the purpose of updating and improving the forced-circulation air coolers manufactured by GEA KÜBA.

2 Technical Data

2.1 Characteristic data

See model designation and label data

GEA Küba Kältetechnik GmbH
 Oberdiller Straße 23 - D-82065 Baierbrunn - Tel.: 089 / 74473-0 - Fax: 089 / 74473-218

Typ / Modell	Artikel-Nr. / Article-No.:	4012.011V	
Herstell-Nr. Manufact.No.	[]		
Ventilator(en) Fan(s)	[]	P _{Gen. Vent. Total Fan}	W
el. Heizung el. Defrost	[]	P _{Gen. Heizung Total Defrost}	W
Rohrinhalt Tube Volume	[] ltr	el. Anschlußwert gesamt el. Connection Value Total	P _{Gesamt Total} W

CE **Ex** **II 2G EEx ec T1-T3**

max. zul. Druck PS_{max} [] bar Fluid Gruppe []
 max. all. Pressure Fluid Group

max. zul. Temp. TS_{max} [] °C min. zul. Temp. TS_{min} [] °C
 max. all. Temp. min. all. Temp.

The following data are shown on the nameplate:

- Type designation (see 2.4 for the type key)
- Serial number, year of manufacture
- Electrical supply
- Electrical power (real)
- Maximum permissible pressure PS
- Maximum permissible temperature TS_{max}
- Minimum permissible temperature TS_{min}
- Permissible fluid group – see 1.2 Application area
- Marking of ATEX type apparatus – in acc. with EC Directive 94/9/EC (only for ATEX type apparatus)
- Additional test markings (e.g. VDE) may be shown

2.2 Range of application and purpose of destination

CAUTION !

The forced-circulation air cooler is suitable only for refrigeration system application according to DIN EN 378. Any use beyond this application is considered as not being in accordance with the purpose of destination. The manufacturer can not be held responsible for damages resulting from such improper use which is exclusively at the risk of the operator. The coolers may be operated only in places where their material cannot be affected by corrosive atmosphere.

2.3 Material data

- Tubes of copper (stainless steel), fins of aluminium. Option: Epoxy resin coating or copper (welded)
- Tube systems are soldered or brazed.
- Suitable for all the refrigerants listed on the name plate, water and glycol water.
- Whilst using secondary refrigerants corrosion inhibitors are to be added where applicable.
- Further information can be found in our sales brochures

2.4 Model designation

For more details see sales brochures

Example: SG _ _ _ C

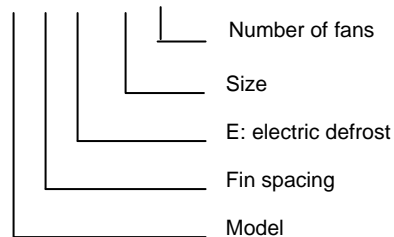

3 Safety

The information given refers to the component „air cooler“ but not to the entirety of the machine unit which incorporates the component.

The heat exchanger of the forced-circulation air cooler is dried using dry air and sealed without over-pressure after the leakage and over-pressure test at the manufacturer.

3.1 Information on safety in general

CAUTION !

The forced-circulation air cooler has been designed according to the latest technical standards and is therefore safe to operate. The air cooler may only be used as described in the manual.

A cooler wrongly installed by unqualified persons for inappropriate application can nevertheless pose a hazard.

The information provided on the nameplate, i.e. max. permissible pressure, permissible temperature and the fluid group, must be ensured by the manufacturer of the plant. The integration and safeguarding of the air cooler must be carried out by the plant manufacturer in acc. with his hazard analysis for the plant, with due consideration of the DIN EN 378 standard and national regulations.

EC directives 94/9/EC (ATEX) and the Ordinance on Industrial Safety and Health must be observed if operated in explosive atmospheres. Only ATEX model forced-circulation air coolers may be installed and operated in explosive atmospheres.

The information provided on the nameplate of the ATEX model forced-circulation air coolers referring to the explosive group, category and temperature class must be taken into account.

CAUTION !

With regard to refrigeration or electronics, the forced-circulation air cooler may be installed only by skilled personnel of specialized firms listed in the register of qualified craftsmen.

Each person employed by the user being entrusted with the mounting, disassembling, starting, operating, and maintenance (inspection, servicing, repair work) of the cooler, must have read and understood the complete „OI“ instructions and in particular the safety instructions according to DIN EN 378 or rather the relevant national standard rules.

For the use of R717/ammonia (with stainless steel tubing only) the relevant provisions must be observed and personal protective equipment is to be used.

3.2 Mounting

The bearing capacity of on site-installed suspension systems (such as threaded rods or brackets) is the responsibility of the installer. For refrigeration installations, the relevant regulations for the prevention of accidents, in particular DIN EN 378, or the relevant national laws and regulations in the particular country must be observed.



Before starting the unit, make sure that all protective devices, especially those regarding the mounting of the fan guard, are fixed.

For mounting, repair, and maintenance work, disconnect electric voltage on all circuits. Be sure to avoid any contact with sharp fin edges. Attention: Danger of injury!

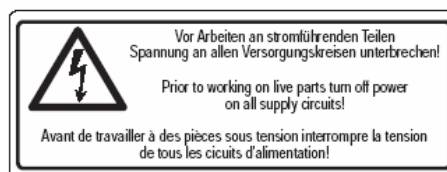
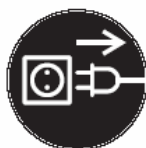

Unauthorized constructional changes and modifications with effect on safety and capacity of the air cooler are not permitted. Be sure to avoid any contact with refrigerant! No brazing or soldering on refrigerant-charged installations. Attention: Danger of poisoning! In case of liquid refrigerant getting in contact with the eye, be sure to see a doctor immediately!

3.3 Mounting of electric parts

For the electric installation, the VDE 0100 and the DIN EN 60204 part 1, the local energy supply networks, and all other safety standards, as well as label data of the fan motors and of the electric defrost system must be noted.



The electric installation may be installed only by electrotechnically instructed personnel of specialized firms under consideration of local electrotechnically regulations.

Wiring should be carried out only in accordance with the wiring diagrams inserted in the mounting instructions and enclosed in the connection boxes of the motors

The only binding data are those on the name plates of the equipment.
For electric defrost, a fault current breaker is additionally required.

An existing thermal protection contact to protect the fans is included either in the electrical supply for the motors or must be included in the electrical control of the motors by the refrigeration system contractor (see wiring diagram for the fans).

CAUTION !

A divider with at least 3 mm contact gap width on each pole must be built into the installation (master switch or service switch).



After the appropriate mounting or repair of the electric parts, the relevant protective measures have to be tested according to DIN EN 60204 part 1.
Tight sealing and traction relief of feed lines must be observed.

4 Transportation

4.1 Packing

4.1.1 Type of packing

The transportation itinerary and size of an air cooler are, among others, two important aspects to be considered in the choice of right packing. The packing corresponds to the guideline mentioned under 4.1.1.1 and 4.1.1.2 unless otherwise agreed.

4.1.1.1 Cardboard packing

The cardboard-type of packing is based on the definition of quality for corrugated fibreboard packing of the Association of the fibre-board industry VDM standards - the DIN 55 468.

4.1.1.2 Pallets, crates, export boxes

These are in accordance with the HPE packing rules which have been defined by the German Federal Organisation for the use of Timber, Pallets, Export Packing Inc., and the Corporation of German Engineering Institutes.

4.1.2 GEA KÜBA transport packings

These are manufactured from ecologically sustainable material apt for reutilisation after recycling.

4.1.3 Packaging regulations



In compliance with the German packaging regulations, we are prepared to take back our packaging materials within the framework of the area of validity, if they are returned carriage paid Baierbrunn. All cardboard packaging used by us is marked with the RESY symbol (return system).

But to avoid any form of waste tourism, we suggest that you, the recipient of the goods, dispose of the packaging by your own initiative.

4.1.4 Pictorial symbols

The pictorial marks on the packing have to be observed, such as:



Top



Fragile



Keep dry

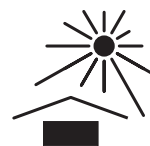

Keep away from heat

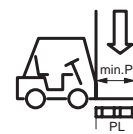

Hold-on points under pallet for forklift



No hand hooks!



Gravity point



Stop device



Stacking Height



No hold-on points under pallet

4.2 Disassembly status

Shipment of the air coolers as completely assembled units is the rule we seek to follow. However, in case the air cooler is delivered disassembled, the mounting must be carried out by following the drawings which are strictly related to the particular order.

4.3 Transport

4.3.1 Handling with adequate care in transit, lifting and storing

During transport, special care must be taken to avoid damage as a result of violence or of careless loading and unloading.

CAUTION !

Strictly avoid any harsh setting down of the cooler. Do not pull on any tubes or connection pieces nor use them for fastening. This may cause leaks.

Carrying ropes, chains, etc. may be fastened only on the adequate suspension points or hoisting brackets. For fork lifting watch the fork arms to be long enough to reach completely under the bottom planks of the item.

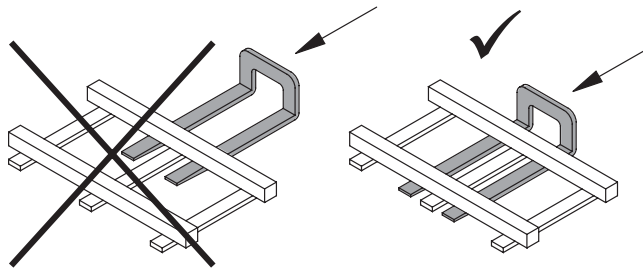

Usually, the coolers are brought into site, packed, with their hangers for ceiling suspension pointing downwards (upside-down position).

Some models are delivered packed in their mounting position. The bottom planks of the crate keep the packed unit high enough leaving space for the forklift to reach out under the bottom planks to lift the item.

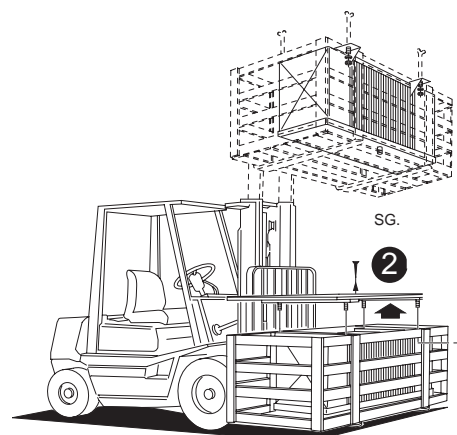
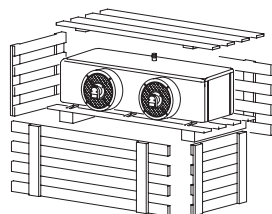
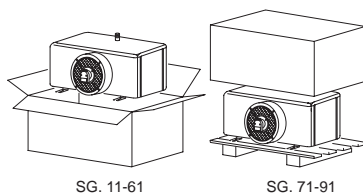

4.3.2 Centre of Gravity



Before lifting the unit, watch out for the weight distribution. The centre of gravity is always the fan side.

4.4 Storage in transit

4.4.1 Storage place

The air coolers should be stored in a protected place unaffected by dust and humidity.

4.4.2 Stacking

The stacking height is printed on the packing. It is important that only units of the same size be stacked one upon the other.

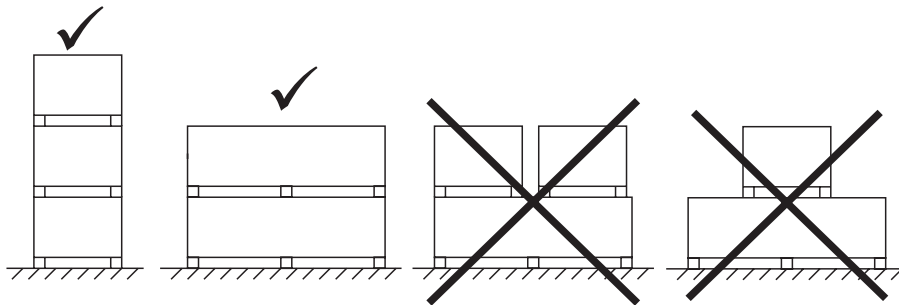

4.5 Volume of delivery

The contents of the packing must be checked for completeness on arrival. Any transport damages and/or missing parts must be reported immediately in writing.

4.6 Securing loads by safety devices



The VDI standards 2700 „Securing Loads on Road Vehicles“ are respected by us. Bulk shipments are the responsibility of the forwarding agent.

4.7 Rules for the prevention of accidents:



The respective national rules for the prevention of accidents must be complied with; e.g. concerning

- lifting devices
- cranes
- cargo carrying devices in lifting service
- powered conveyor vehicles

5 Mounting

5.1 General instructions for mounting

CAUTION !

All mounting work has to be carried out exclusively by skilled personnel. We expressly decline all responsibility for damages resulting from inexpert mounting.

The air cooler must be fastened only at the suspension point provided for this purpose.

The pictures given in our literature are simplified.

A copy of the specific mounting instructions is enclosed with each forced-circulation air cooler. Current versions can be downloaded from our website www.kueba.com.

Montageanleitung

DE.D

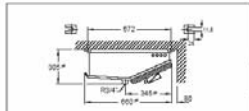

- ☰ Mounting Guide
- ☑ Guide de montage
- ☑ Instrucción para el montaje
- ☑ Instruções para a montagem
- ☑ Istruzioni per il montaggio
- ☑ Handleiding voor montage
- ☑ Οδηγία συναρμολόγησης
- ☑ Montage Vejledning
- ☑ Instrukcja montażu
- ☑ Инструкция по монтажу

DE.D	[mm]					☰
	B	E1	E2	DE.A.D	DE.B.D	kg
071	1080	730	-	18,1	15,6	
081	1080	730	-	19,4	17,1	
091	1080	730	-	21,5	18,7	

DE.D

① → ① → ② → ③ → ④

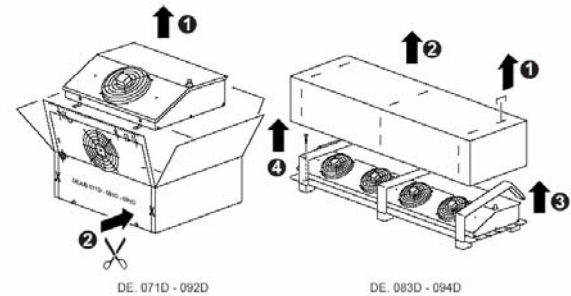

5.2 Set-up conditions

5.2.1 General set-up instructions

CAUTION !

Mounting requirements which are mentioned within DIN EN 378 standard or the relevant national laws and regulations in the particular country must be observed.

It is very important to reserve, in the floor space plan, sufficient room around the cooler for mounting, function, servicing, and repair work.

Ceiling or wall should be prepared in advance, according to weight and number of fastening points of the cooler.



The bearing capacity of the suspension systems (such as threaded rods or brackets) and the strength of the bolts is the responsibility of the installer.

The suspension points are printed on the cardboard boxes or rather may be found in mounting instructions.

5.2.2 Dimensions, floor space and weight

Dimensions:

See planning aid literature or mounting instructions.

Floor space required:

Provide for additional space on the connection side for exchange of the tubular heaters (measurement B).

A free air intake and outlet space should be provided with enough distance to wall and ceiling, ceiling joists, stacked products, shelves etc. for dimensions see also planning aid literature and mounting instructions.

If the space is kept too narrow, this may lead to malfunctions in the system.

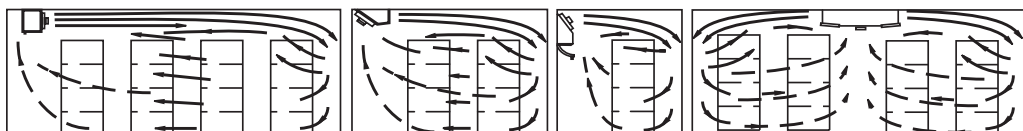

Weight:

See planning aid literature or mounting instructions.

5.2.3 Hoisting devices



The bearing capacity must correspond to a weight which is at least 1½ times the unit.

5.3 Mounting work

5.3.1 General information on mounting works

See section 3.2.2

5.3.2 Mounting of electric parts

See section 3.2.3

5.3.3 Mounting of accessories

See mounting instructions as enclosure with accessory parts

5.3.4 Mounting of refrigeration equipment

CAUTION !

Mounting of tubes in accordance with DIN EN 378. Be sure not to transmit any tensions or vibrations on the cooler.

Cleanness and dryness of the air cooler is in accordance with DIN 8964 standards. Strictly avoid inner contamination of the duct work during installation of the plant.

For mounting of the solenoid valve follow instructions of the manufacturer.

For hot gas operation, it will be necessary to use special air coolers with special tube circuitry. For hot gas defrost, the air coolers have to be integrated into the plant in accordance with the following schemes (for description please see planning aid).

5.3.5 Positioning of the defrost sensor



The position of the defrost sensor proposed by Küba for conventional operating conditions is marked with a sticker on the end plate. A pocket is provided here for the sensor in the coil.

5.3.6 Finned tube heaters

CAUTION !

If additional heaters are installed on the forced-circulation air cooler, such heaters must be safeguarded with a suitable temperature limiting system in the installation room.

The heaters may only be operated when the fans are running, together with the standard air straightener.

The electrical cables to the finned tube heaters must not exceed a maximum temperature of 120 °C. A corresponding delay must therefore be provided after the heaters have switched off and before the fans switch off.

6 Starting Operation

6.1 Instructions



The starting operation may be effected only by skilled professional personnel and only after conducting a leak test in accordance with DIN EN 378 regulations

6.2 Test run

CAUTION !

Be sure to control the current absorption as per label data and the sense of rotation of the fans.

SÜD-ELECTRIC GmbH Eglharting						CE
Type			Nr.			
V ±10%	Hz	A	W _{abs}	U/min	cos φ	VDE 0700
Is.-KI.	-Mot	IP	S 1	C =	μF	-40/ +45°C

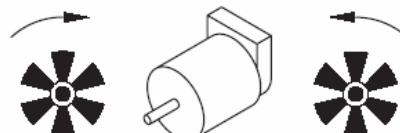

CAUTION !

Test all connected control devices for correct performance.

CAUTION !

Test the safety devices for ON and OFF switching points.

6.3 Testing before start-up

If necessary, the operating company shall prove that the authorised person has tested the forced-circulation air cooler before start-up in accordance with the Ordinance on Industrial Safety and Health. The Declaration of Conformity required for this purpose is available as a file for download on the Internet.

6.4 Purging the cooling / heating circuits

When filling the cooling / heating circuits, ensure that there are no air pockets in the respective circuits. Suitable purging arrangements must be provided to vent gases released from the cooling / heating medium during operation.

7 Operation

7.1 Use as intended

7.1.1 Direct expansion

The forced-circulation air cooler is charged with refrigerant via injection valve. The liquid evaporates in the tube system, changes the physical status and takes on heat through the wall of the tube. The cooled-down metal walls and fins of the cooler take over the heat from the „warm“ air which is in the cold room. The heat transferred to the cold room will again be extracted by the forced-circulation air cooler.

7.1.2 Water and glycol water operation

Liquid refrigerant eased on low pressure is forwarded by a pump or by gravity into the tubing of the air cooler. The liquid refrigerant vaporizes in the tubing of the heat exchanger by warmth carried in over the fins and into the tube wall from the atmosphere.

7.1.3 Secondary Refrigerants

For water and glycol water operation the air cooler to be used must be of a special kind and with special tubing circuitry.

The refrigerant flowing through the heat exchanger tubes absorbs ambient heat through the tubes and fins.

7.2 Shutdown of the forced-circulation air cooler:

The forced-circulation air cooler is a part of the refrigeration plant.

The shutdown and the re-start is effected by the specific plant version in accordance with the installers operating instructions.

CAUTION !

If the motors in the cold room are shut down for longer, we recommend 2 runs of 1-2 hours each per month.

7.3 How to handling failure situations



Use the personal protective gear when refrigerants are escaping!

Strictly avoid all contacts with the refrigerant!

In case of any contact of liquid refrigerant with the eye, be sure to see a doctor immediately!

Servicing and repair work should be carried out only by skilled professionals.

7.4 Recurrent tests

The authorised person must perform regular tests on the Küba forced-circulation air coolers in accordance with the hazard evaluation of the operating company (Ordinance on Industrial Safety and Health). If necessary, the leakage test must be performed in acc. with the national regulations.

The tests listed in the Annex should be performed at intervals as determined in the experience of the operating company.

8 Maintenance

GEA KÜBA forced-circulation air coolers, in general, are maintenance-free. However, in accordance with hygiene standards, resulting from the respective application, the forced-circulation air cooler should be cleansed at intervals.

The degree of dirt contamination affects the efficiency of any air cooler. •Consequently, the unit should be cleansed regularly with material-compatible detergents.

Only cleaning agents compatible with the materials used in the forced-circulation air cooler may be used, considering of the manufacturer's application instructions (e.g. mixing ratio, exposure time, after-treatment).

In case of vapour-bath or high pressure cleansing, electrical parts should not come under direct air blast.



Prior to all maintenance and cleansing works, the electric connections must be off the mains.

Be sure to read the label with the safety instructions on the air cooler.

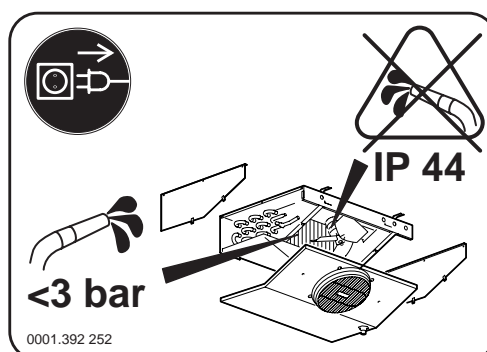



Depending on the fluid used, caustic, toxic, flammable or explosive substances may develop when welding or soldering on the heat exchanger. Before soldering or welding on the heat exchanger, remove residual gases from the heat exchanger and rinse the tubes with an inert gas such as nitrogen.

9 After-Sales Service

9.1 Stock keeping of spare parts

Stock keeping of spare parts and after-sales service are the installer's responsibility. Refer to the current spare parts list for spares.

9.2 Corrosion

GEA KÜBA GmbH shall not be held responsible for limited shelf life as a result of application in corrosive atmosphere, even not in those cases where variants of corrosion-preventive combinations have been used already.

10 Disassembling and Recycling

10.1 Disassembling

For the disassembly of refrigeration units the relevant accident prevention rules according to DIN EN 378 - must be observed.

10.2 Materials of the air cooler

The use of materials such as copper, aluminium, steel and stainless steel prevails. Within the waste disposal industry, such metals can be reused even painted, for recycling via mechanical and/or thermal separation.

10.3 Synthetic construction materials

Fan guards, fan guard brackets, air straightening grilles and air straightening ducts, fans and connection boxes are made of polyamides, partly of fibre glass. This material is fully recyclable.

10.4 Materials of motors

With the exception of few insulating parts, steel, aluminium, copper, and polyamides are used. Recycling as described in paragraphs 10.2 and 10.3.

10.5 Packing material

We use untreated timber, cardboard packing bearing the RESY symbol (return system for recycling), styrofoam, and polyethylene foils. These materials are recyclable.

For packaging regulations, refer Section 4.1.3.

10.6 Recycling concept

Paragraphs 10.2 through 10.5 give recommendations. However, the binding laws on recycling are always those in the country of the user.

11 Annexes

- The Declaration of Conformity in accordance with the applicable EC directives can be downloaded at GEA Küba GmbH on the Internet at www.kueba.com.
- The installation instructions for the specific series can be downloaded from GEA Küba GmbH on the Internet at www.kueba.com.
- Compilation of the recurrent tests for forced-circulation air coolers (proposal) in acc. with the DIN EN 307 standard

Checklist for recurrent testing of forced-circulation air coolers

(Proposal)

- Visual inspection of brackets and fastenings
- Checks for external soiling, damage and corrosion
- Leakage test
- Visual inspection of the heat exchanger for icing up
- Checking the refrigerant filling level and sucooling at the sight glass with forced-circulation air coolers with expansion valve
Checking the refrigerant level in flooded forced-circulation air coolers
Condition and filling level of the refrigerant in forced-circulation air coolers with refrigerants
- Measurement of the evaporation and overheating temperature of the refrigerant
Measurement of the inlet and outlet temperature of the secondary refrigerant
- Measurement of the inlet and outlet temperature of the air
- Measurement of the rpm and active power consumption of the fans
- Cleaning of the heat exchanger
- Cleaning of the drip tray
- Checking the functionality / cleaning the condensation drainage
- Checking the functionality of the defrost heater (electrical, hot gas)
- Functional checking of the safety systems (excluding safety valves)
- Functional checking of the shut-off armatures
- If necessary, checking for sufficient concentration of the anti-freeze and secondary refrigerant's inhibitors

The checking periods shall be determined by the operating company based on an evaluation of the hazard and in consideration of the operating conditions.